



Monavar Gostar Espadana.co



Bending types

- CABLE TRAY STRAIGHT NON PERFORATED

LENGTH : from 1m to 3m

WIDTH : from 50mm to 1000mm

HEIGHT : from 20mm to 200mm

THICKNESS : from 1mm to 3mm

MATERIAL : Carbon steel ST37-hot dip galvanized after fabrication

fabric galvanized

stainless steel 304,316,316L

Aluminium

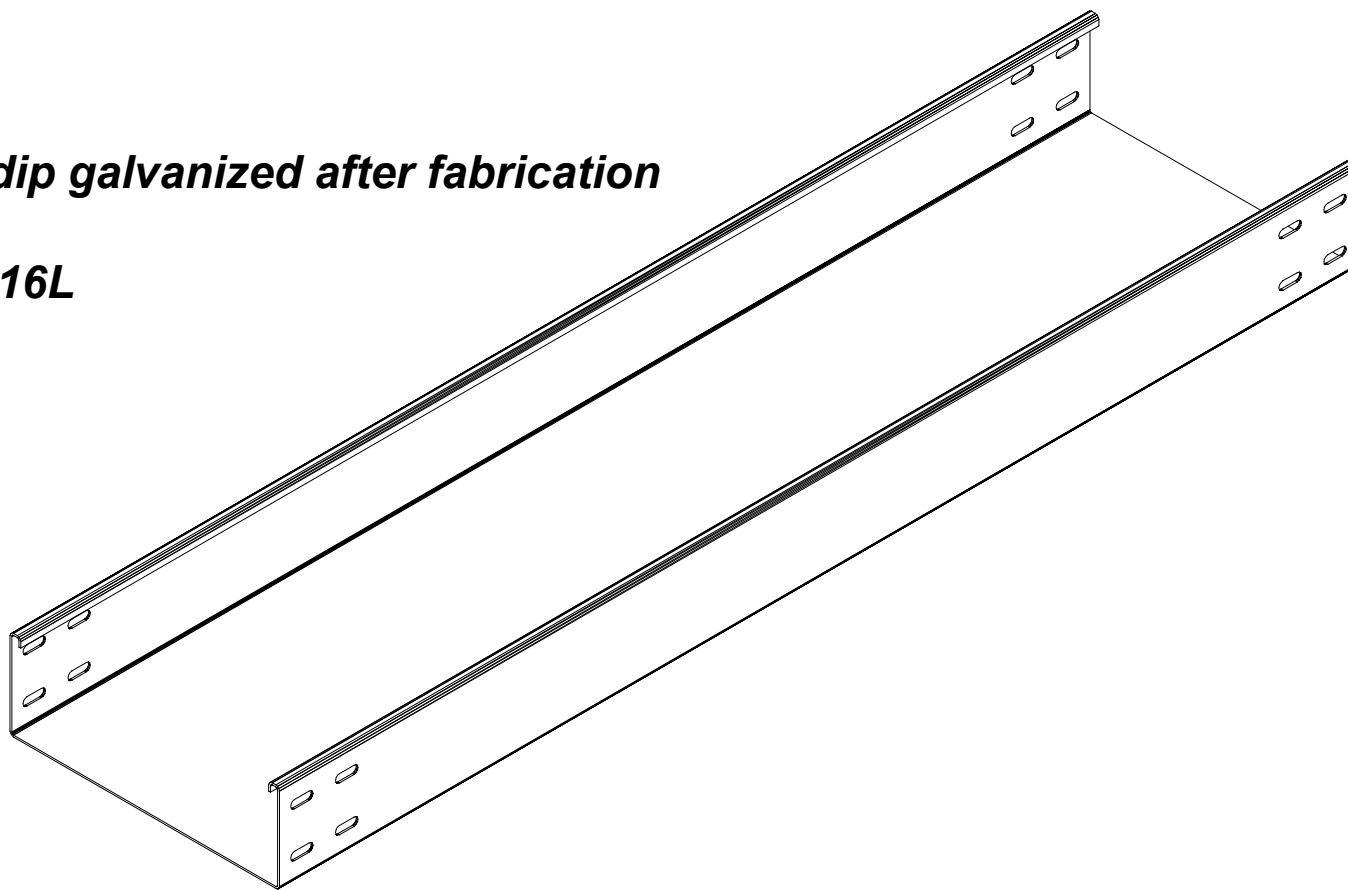



Monavar Gostar Espadana.co



Bending types

- CABLE TRAY STRAIGHT PERFORATED

LENGTH : from 1m to 3m

WIDTH : from 50mm to 1000mm

HEIGHT : from 20mm to 200mm

THICKNESS : from 1mm to 3mm

MATERIAL : Carbon steel ST37-hot dip galvanized after fabrication

fabric galvanized

stainless steel 304,316,316L

Aluminium

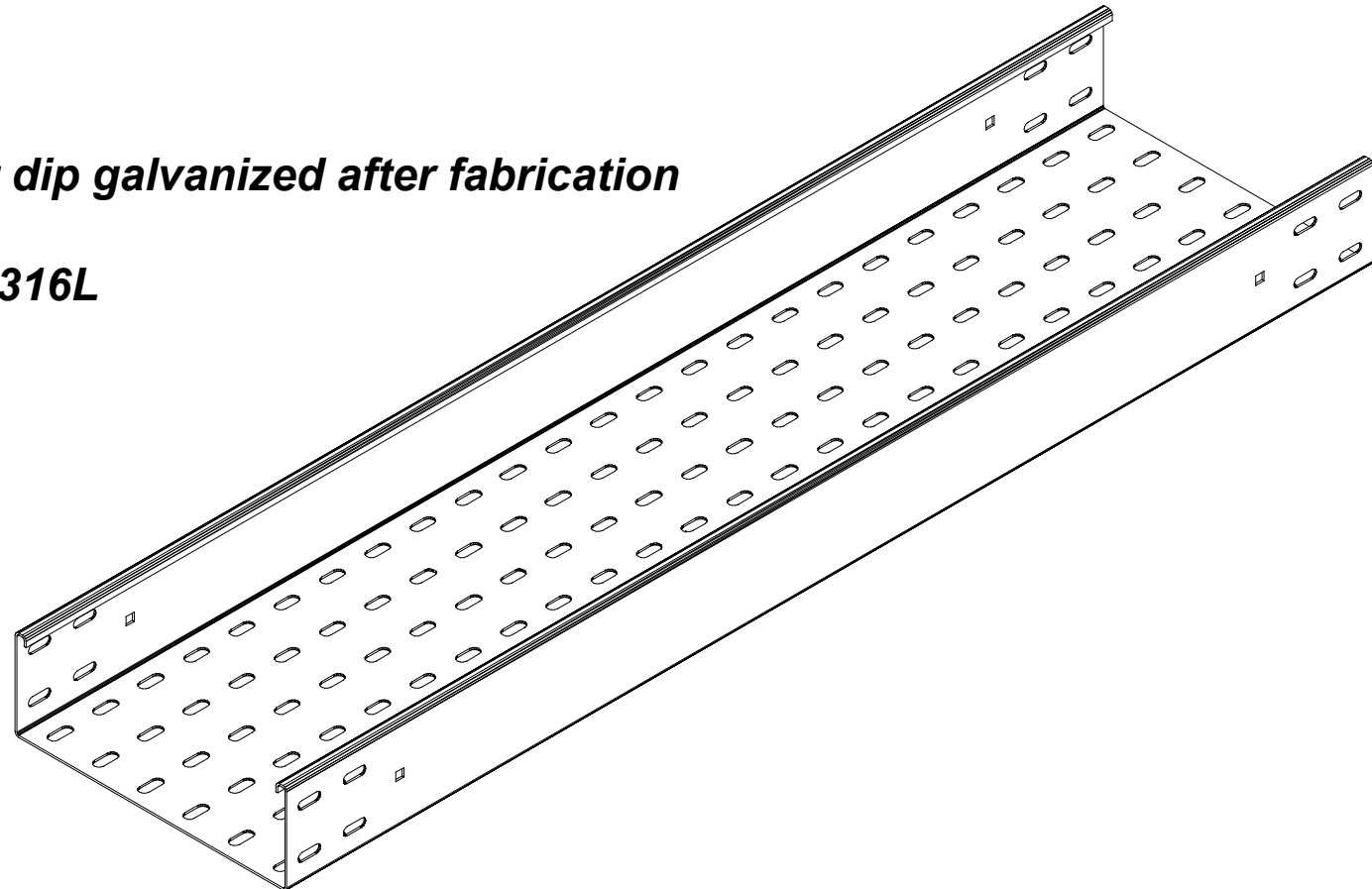



Monavar Gostar Espadana.co



Bending types

- CABLE TRAY STRAIGHT FULL PERFORATED

LENGTH : from 1m to 3m

WIDTH : from 50mm to 1000mm

HEIGHT : from 20mm to 200mm

THICKNESS : from 1mm to 3mm

MATERIAL : Carbon steel ST37-hot dip galvanized after fabrication

fabric galvanized

stainless steel 304,316,316L

Aluminium

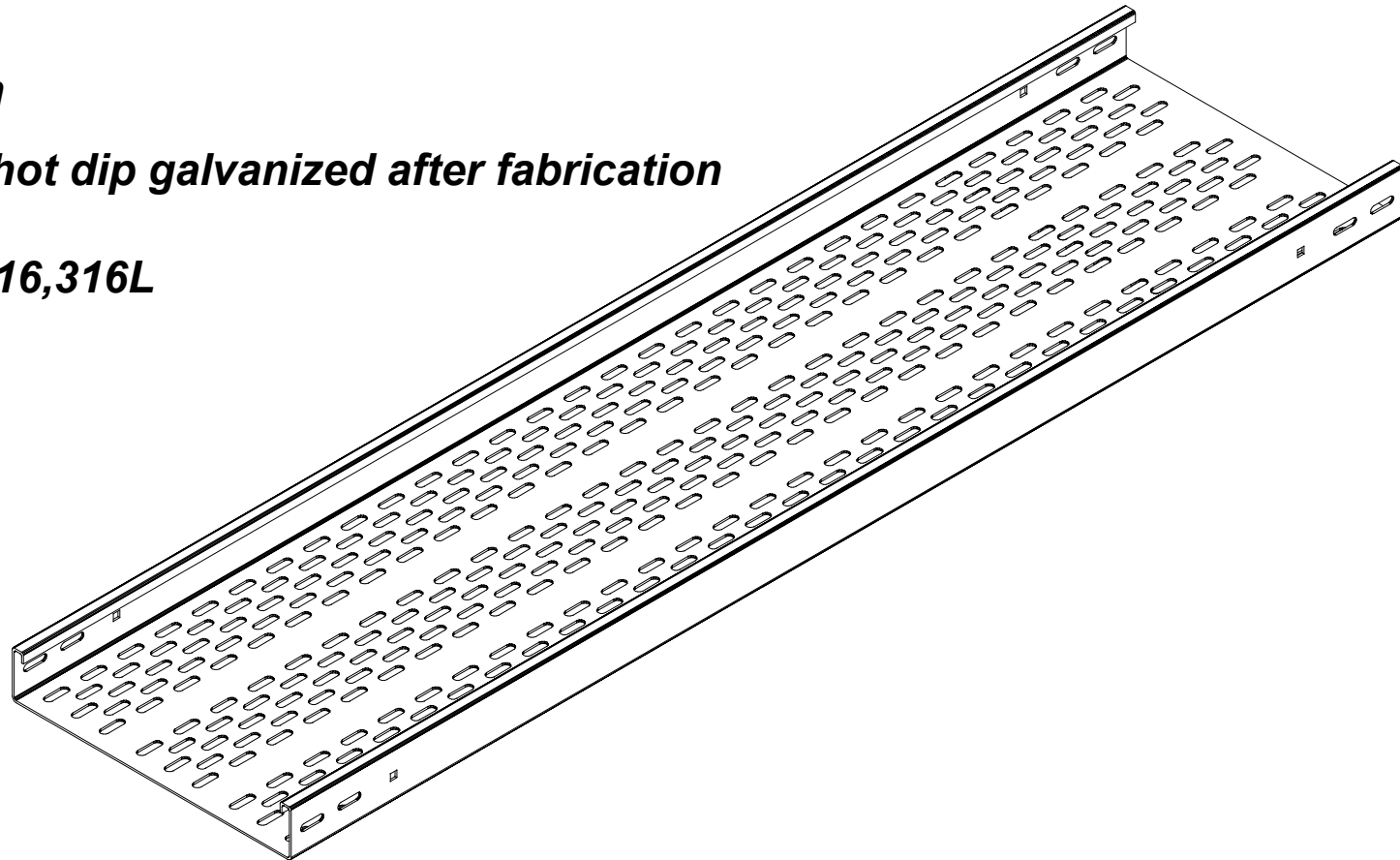



Monavar Gostar Espadana.co



Bending types

- CABLE TRAY STRAIGHT PERFORATED (CROSSOVER)

LENGTH : from 1m to 3m

WIDTH : from 50mm to 1000mm

HEIGHT : from 20mm to 200mm

THICKNESS : from 1mm to 3mm

MATERIAL : Carbon steel ST37-hot dip galvanized after fabrication

fabric galvanized

stainless steel 304,316,316L

Aluminium

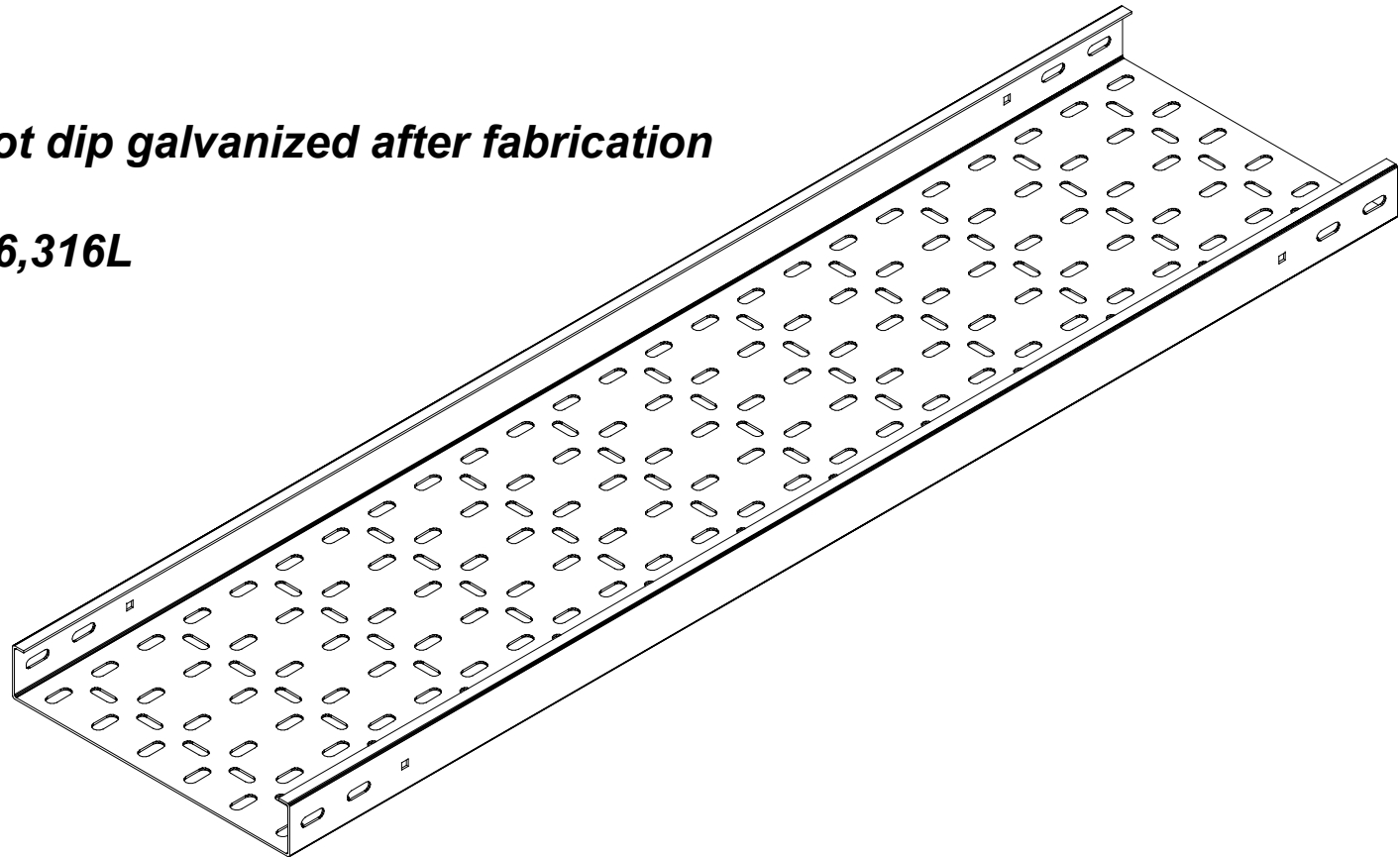



Monavar Gostar Espadana.co



Bending types

- CABLE TRAY STRAIGHT FULL PERFORATED

LENGTH : from 1m to 3m

WIDTH : from 50mm to 1000mm

HEIGHT : from 20mm to 200mm

THICKNESS : from 1mm to 3mm

MATERIAL : Carbon steel ST37-hot dip galvanized after fabrication

fabric galvanized

stainless steel 304,316,316L

Aluminium

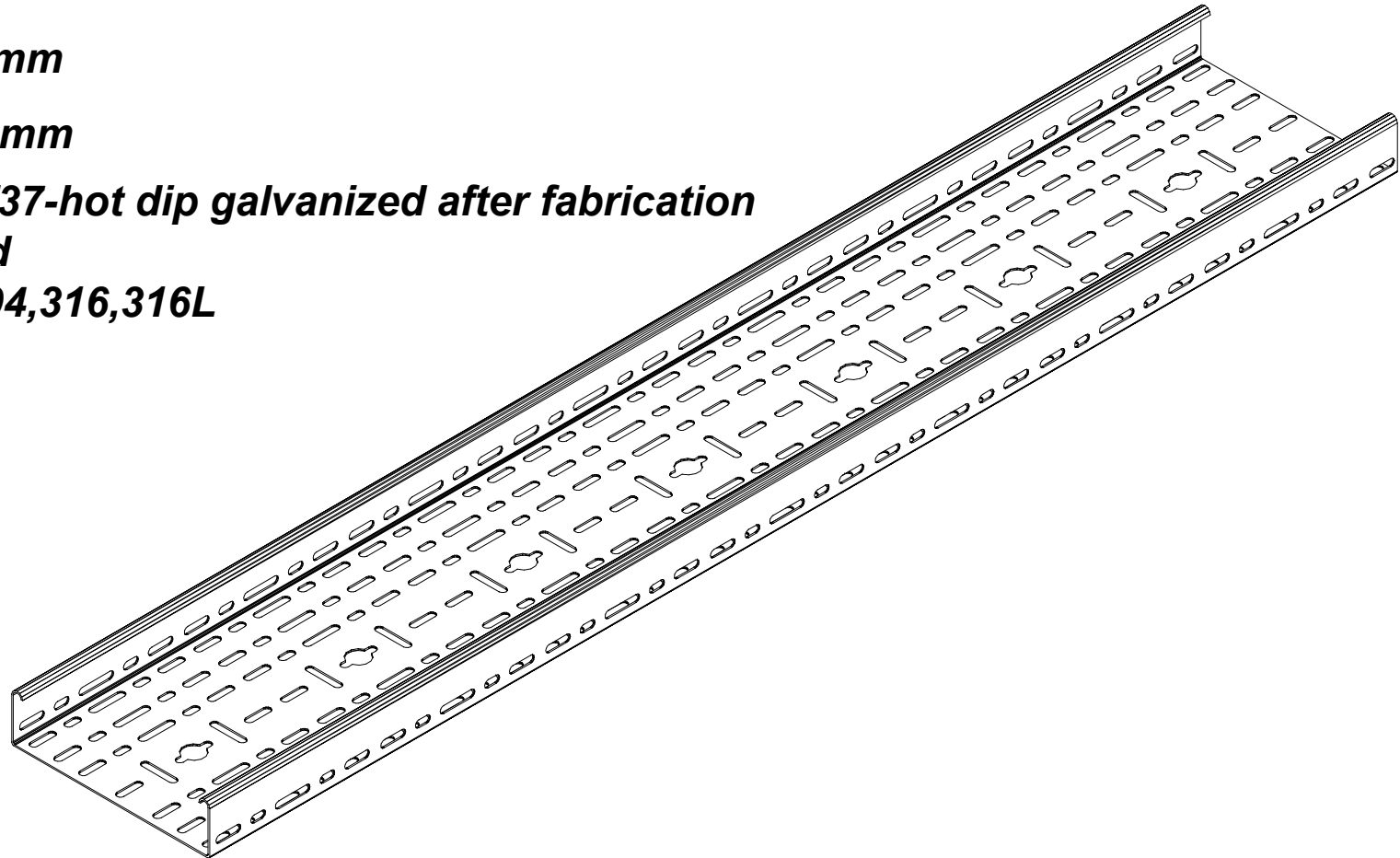



Monavar Gostar Espadana.co



Bending types

- CABLE TRAY STRAIGHT FULL PERFORATED

LENGTH : from 1m to 3m

WIDTH : from 50mm to 1000mm

HEIGHT : from 20mm to 200mm

THICKNESS : from 1mm to 3mm

MATERIAL : Carbon steel ST37-hot dip galvanized after fabrication

fabric galvanized

stainless steel 304,316,316L

Aluminium

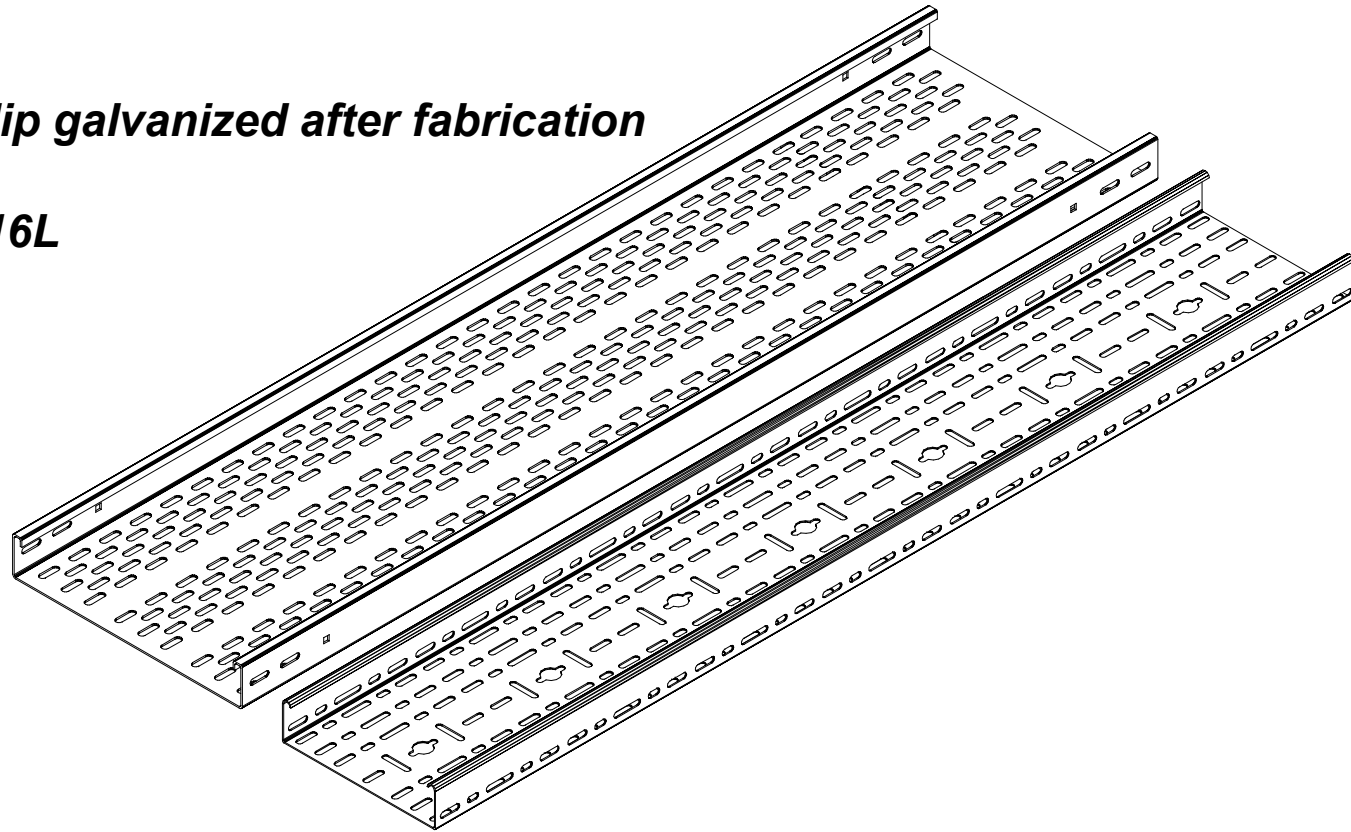



Monavar Gostar Espadana.co

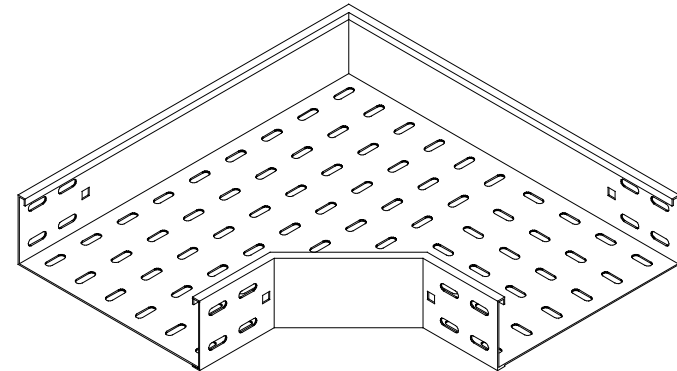
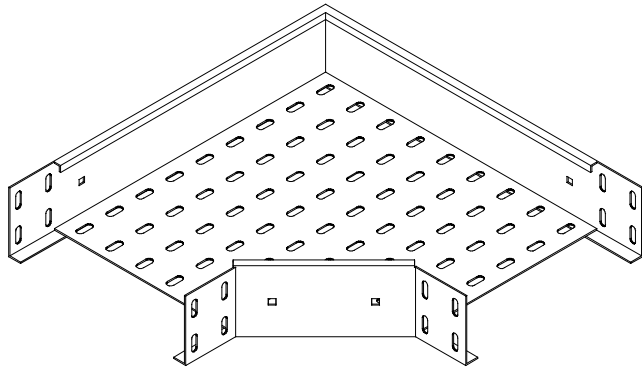
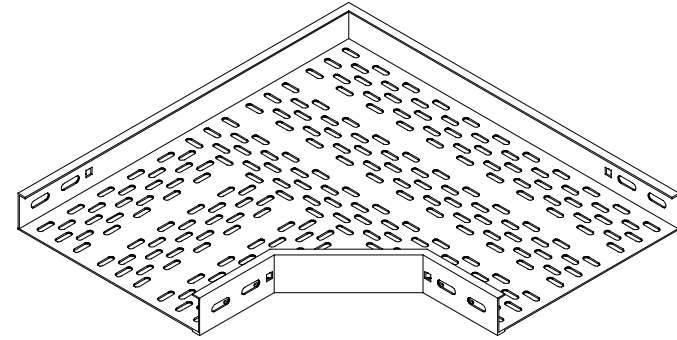
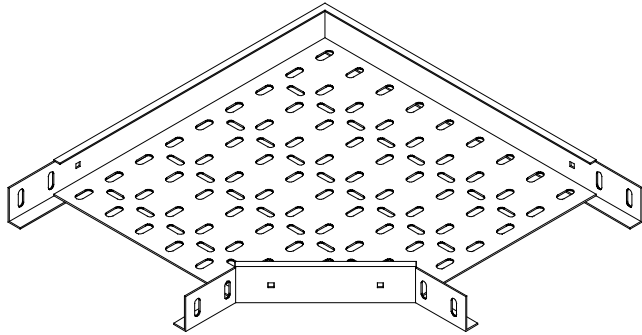
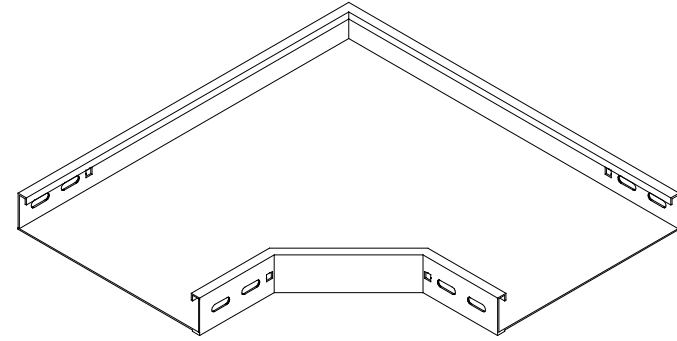
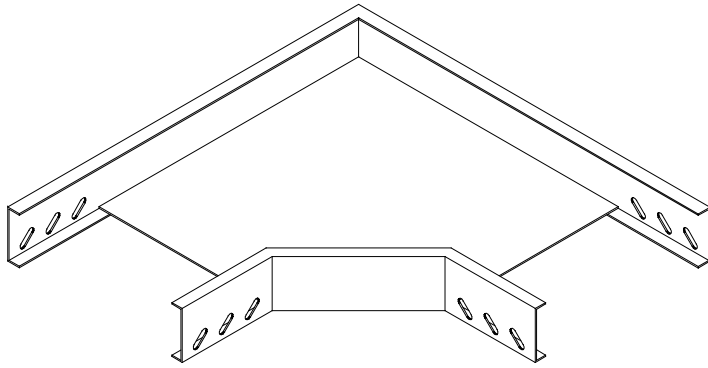

CABLE TRAY HORIZONTAL ELBOW 90°

TECHNICAL SPECIFICATIONS ACCORDING TO THE CABLE TRAY STRAIGHT



Monavar Gostar Espadana.co

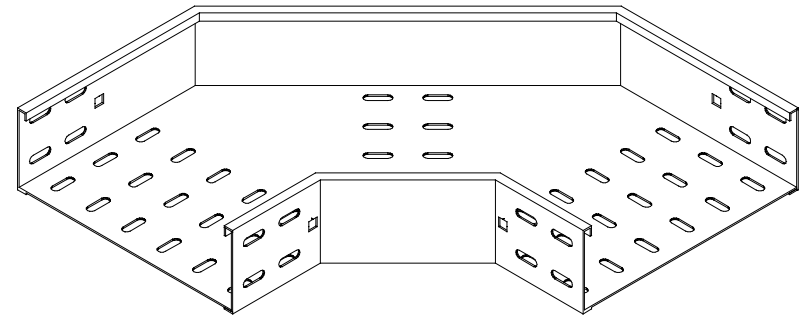
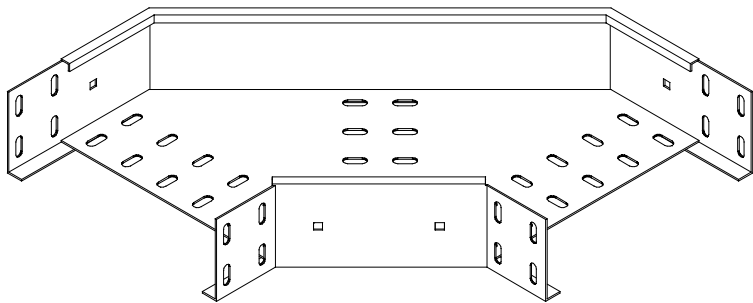
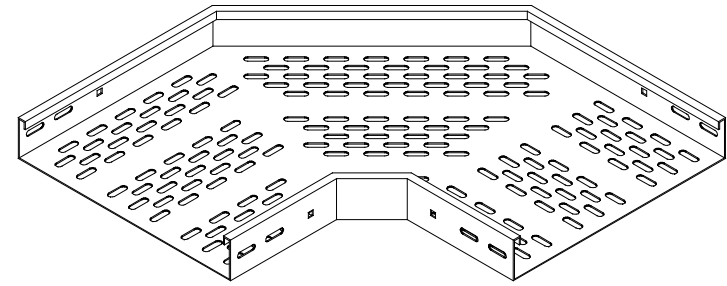
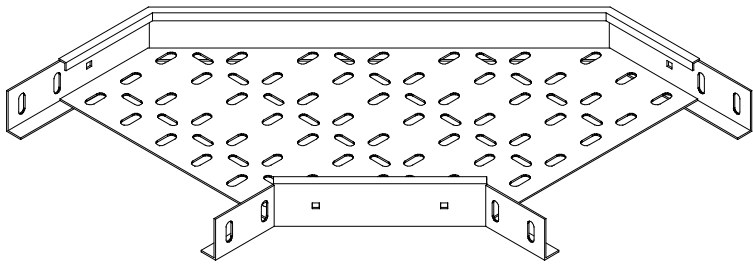
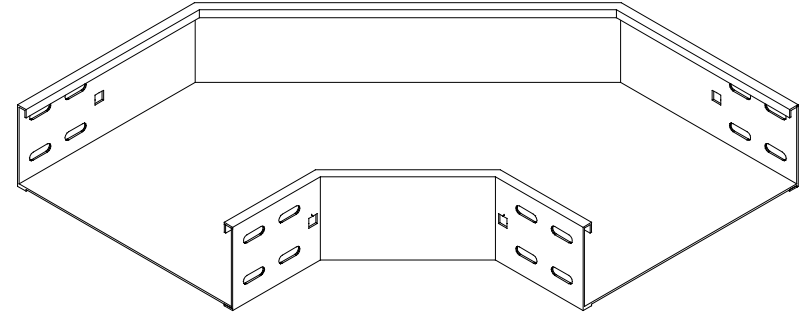
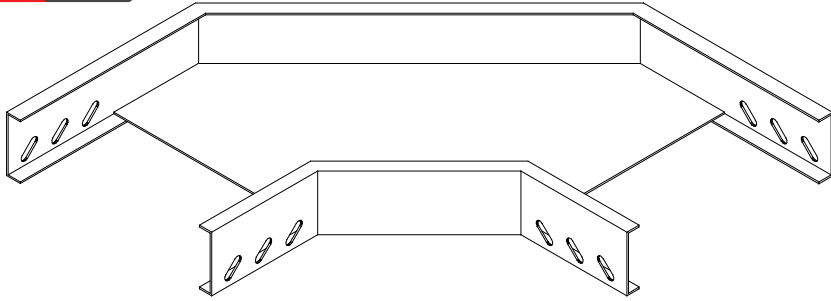

CABLE TRAY HORIZONTAL ELBOW 2*45°

TECHNICAL SPECIFICATIONS ACCORDING TO THE CABLE TRAY STRAIGHT



Monavar Gostar Espadana.co

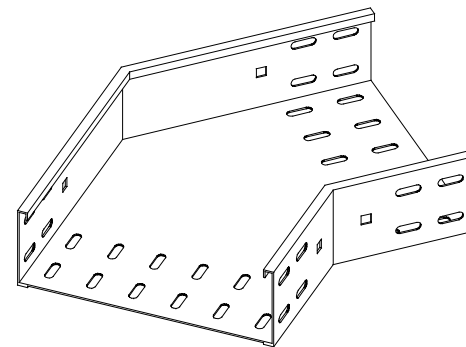
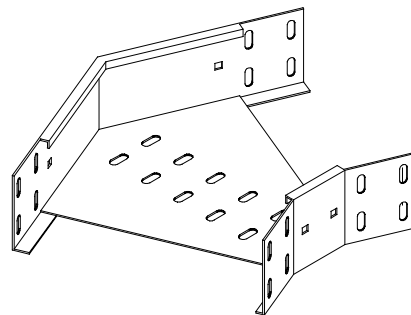
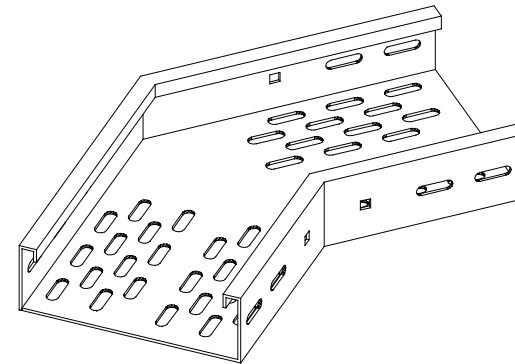
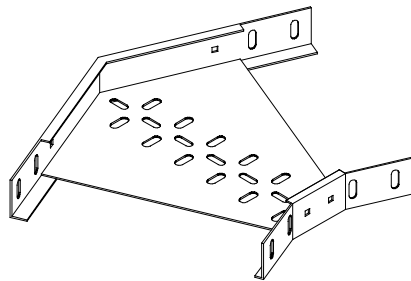
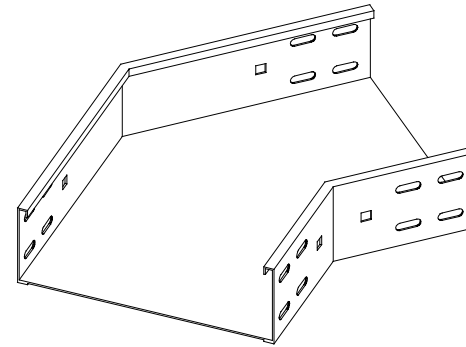
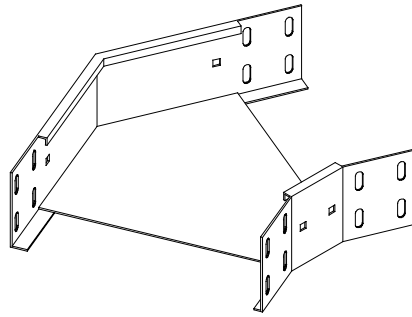

CABLE TRAY HORIZONTAL ELBOW 30-45-60°

TECHNICAL SPECIFICATIONS ACCORDING TO THE CABLE TRAY STRAIGHT



Monavar Gostar Espadana.co

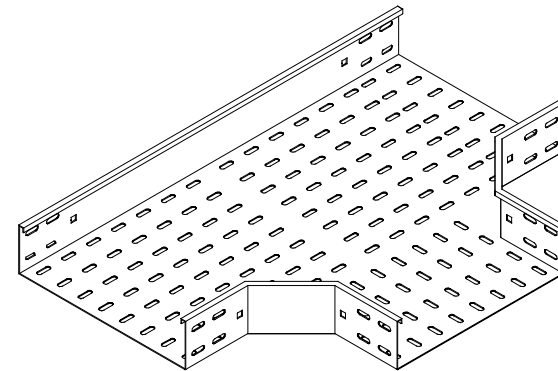
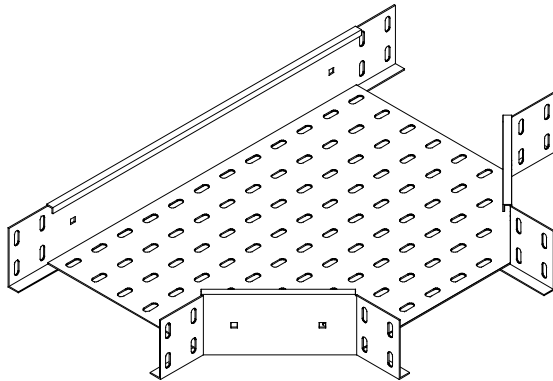
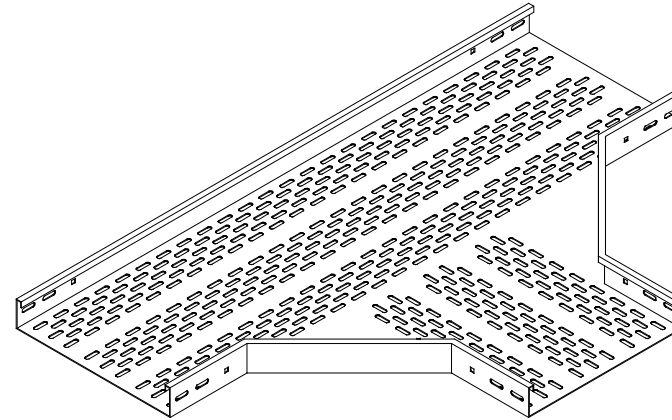
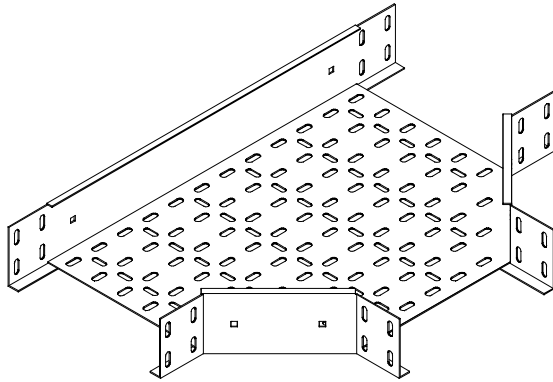
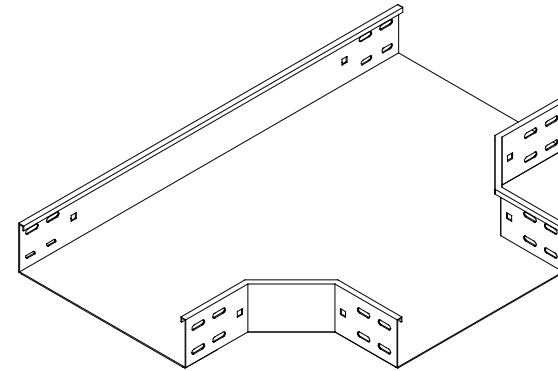
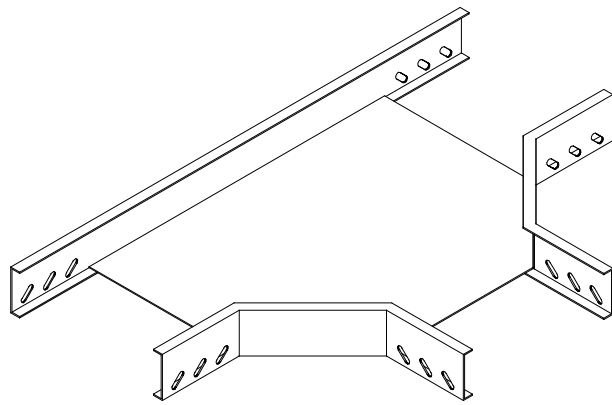

CABLE TRAY HORIZONTAL TEE

TECHNICAL SPECIFICATIONS ACCORDING TO THE CABLE TRAY STRAIGHT



Monavar Gostar Espadana.co

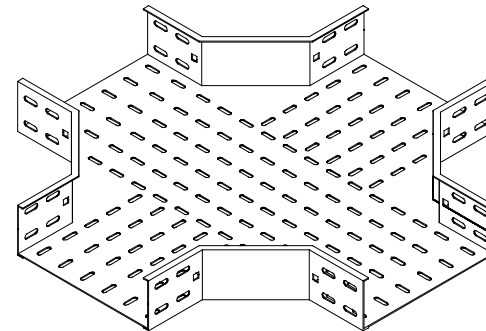
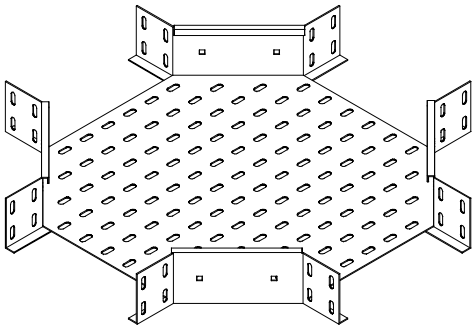
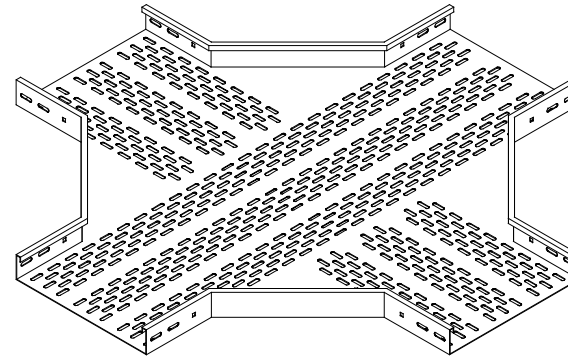
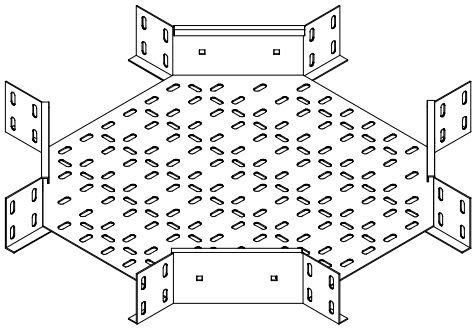
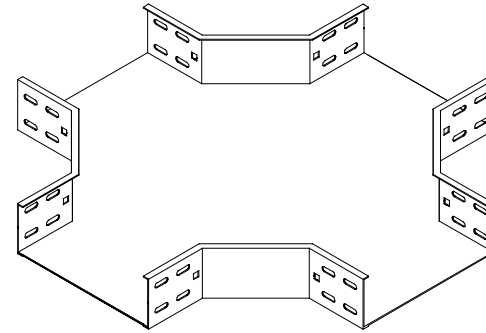
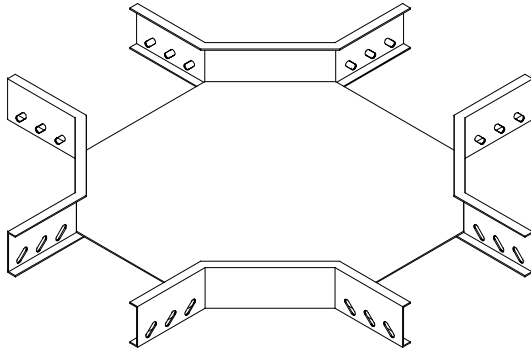

CABLE TRAY HORIZONTAL CROSS

TECHNICAL SPECIFICATIONS ACCORDING TO THE CABLE TRAY STRAIGHT



Monavar Gostar Espadana.co

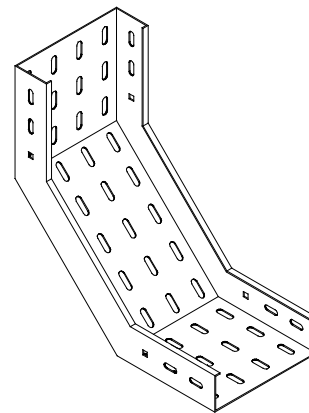
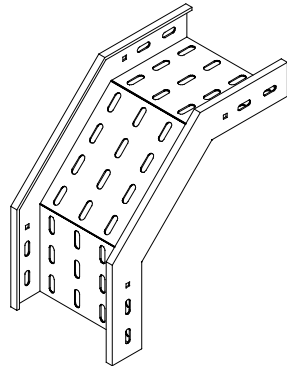
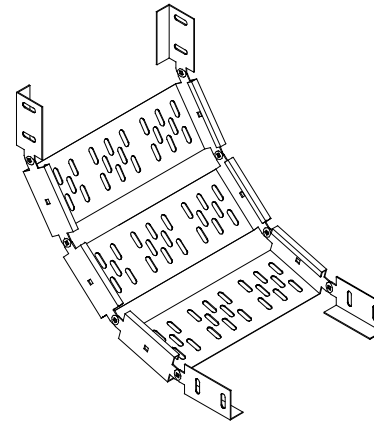
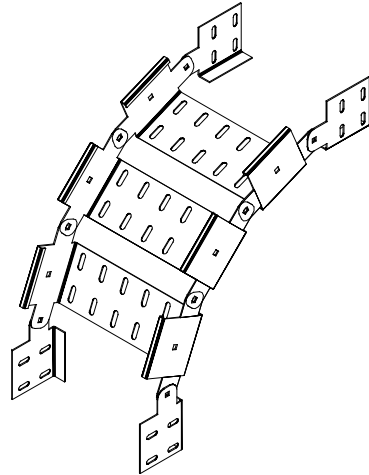
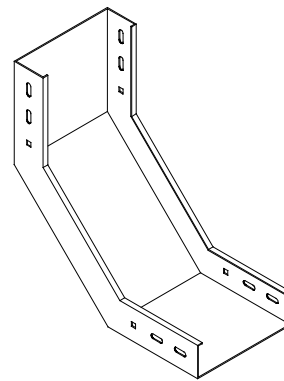
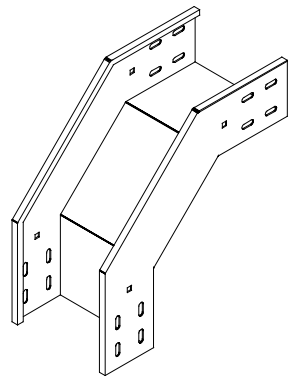

CABLE TRAY VERTICAL INSIDE/OUTSIDE ELBOW 90°

TECHNICAL SPECIFICATIONS ACCORDING TO THE CABLE TRAY STRAIGHT



Monavar Gostar Espadana.co

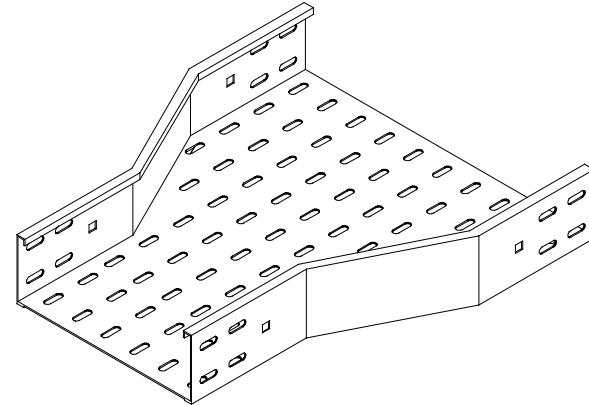
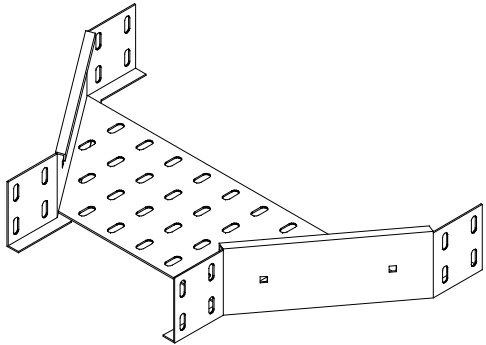
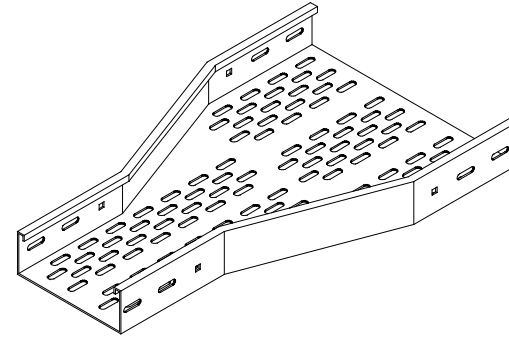
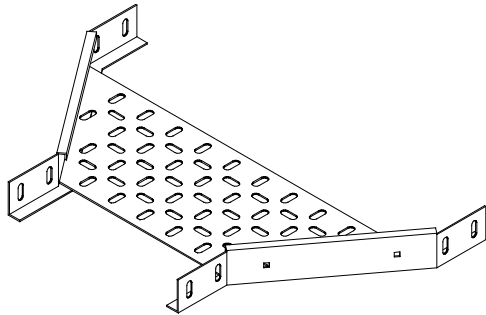
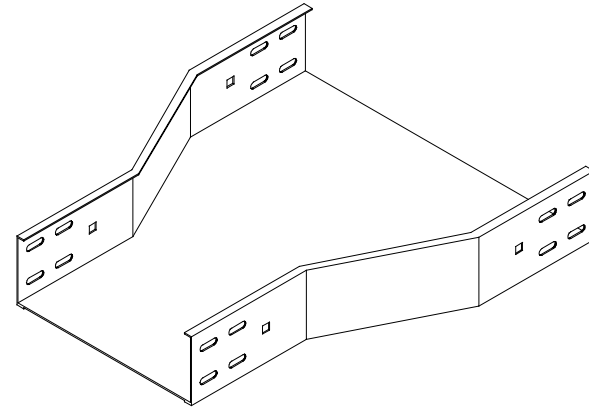
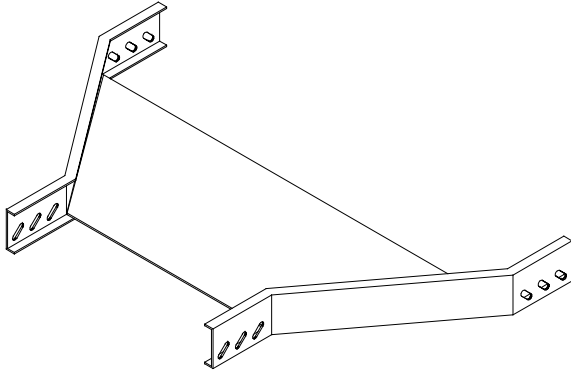

CABLE TRAY STRAIGHT REDUCER

TECHNICAL SPECIFICATIONS ACCORDING TO THE CABLE TRAY STRAIGHT



Monavar Gostar Espadana.co

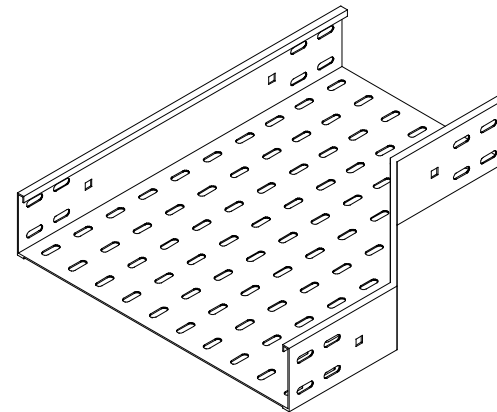
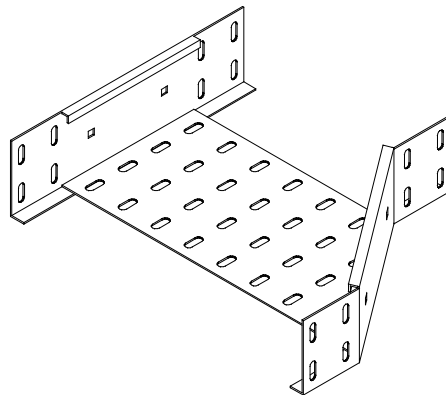
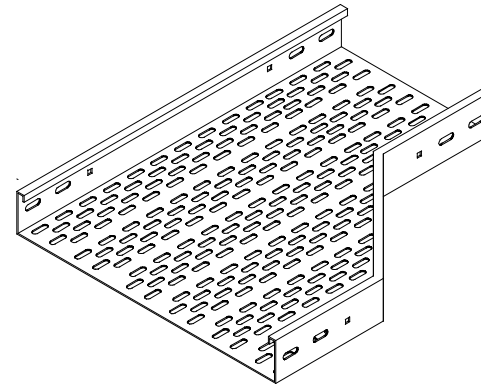
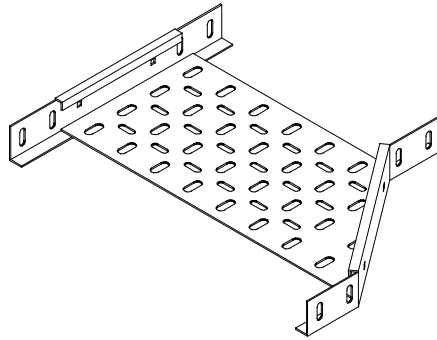
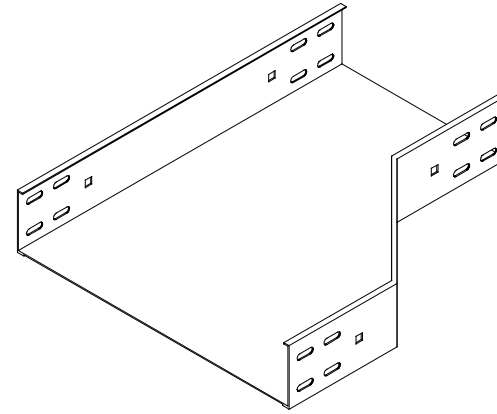
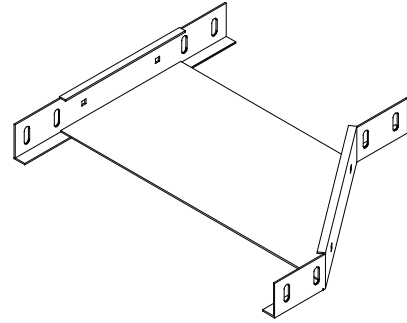

***CABLE TRAY HORIZONTAL LEFT HAND REDUCER
TECHNICAL SPECIFICATIONS ACCORDING TO THE CABLE TRAY STRAIGHT***



Monavar Gostar Espadana.co

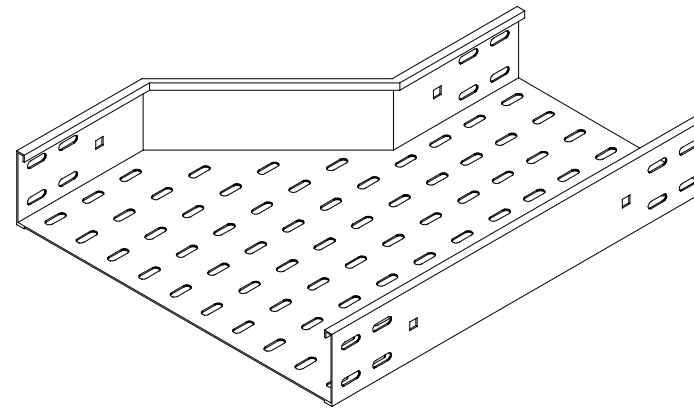
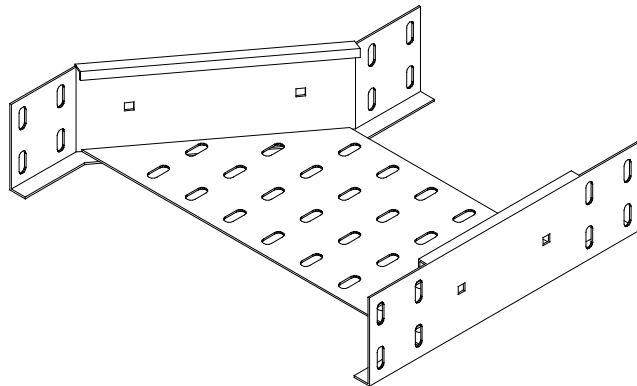
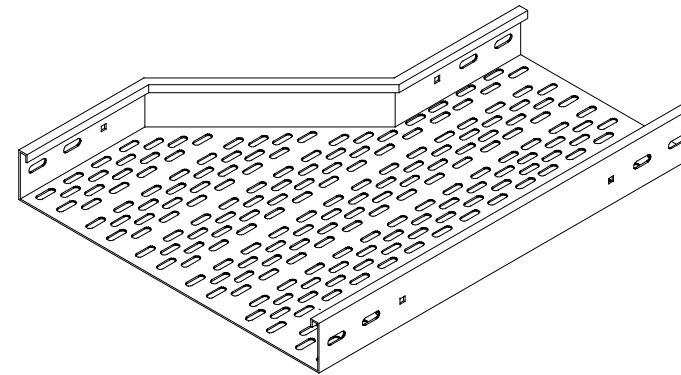
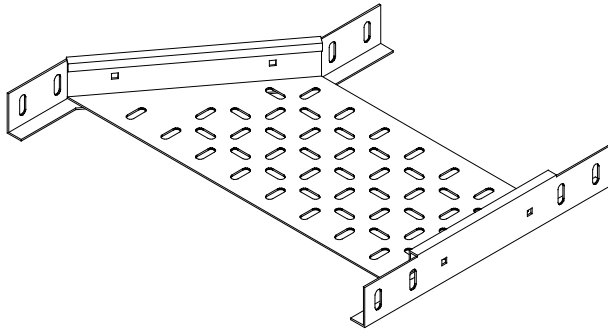
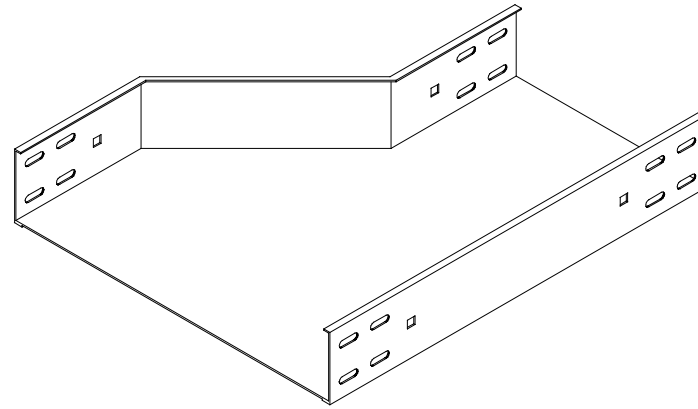
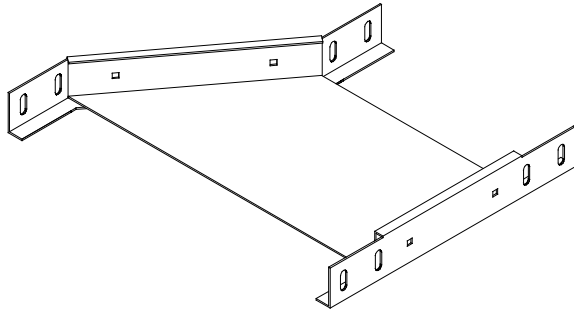

CABLE TRAY HORIZONTAL RIGHT HAND REDUCER

TECHNICAL SPECIFICATIONS ACCORDING TO THE CABLE TRAY STRAIGHT